



DEAD AIR

No Quarter™

OWNER'S MANUAL



WELCOME TO DEAD AIR SILENCERS

Thank you for purchasing our products and supporting the Second Amendment.

Dead Air Silencers was co-founded by one of the industry's true icons, Mike Pappas, and is supported through distribution and manufacturing by our industry partners. The goal of our company is simply to make the best firearm sound suppressors on the market. Every suppressor is manufactured in the U.S.A. by American craftsmen utilizing the finest materials. As Mike says, "We wouldn't have it any other way. We want the best products, made by Americans for Americans." That said, it's our customers that make our products possible and we appreciate each and every one of you that have supported us.

We place an absolute premium on customer service. We demand that our customers receive prompt and rewarding care and support. Feel free to contact us at 844-293-6778 or info@DeadAirSilencers.com with any questions or concerns you may have. Once again, thank you for your support.



TABLE OF CONTENTS

PRODUCT OVERVIEW	4
INSTALLATION	5
BREAK IN	8
DISASSEMBLY & CLEANING	9
DISCLAIMER	10
WARRANTY	10
LAWFUL USE AND POSSESSION	11
CONTACT INFORMATION	11



FIREARMS ARE DANGEROUS! REVIEW THIS OPERATOR'S MANUAL IN FULL BEFORE USING YOUR SUPPRESSOR. FAILURE TO FOLLOW THE INSTRUCTIONS LISTED BELOW COULD RESULT IN DAMAGE TO YOUR FIREARM AND/OR SERIOUS PERSONAL INJURY OR DEATH. DO NOT ATTEMPT TO USE YOUR FIREARM AND/OR SUPPRESSOR UNTIL YOU HAVE THE PROPER TRAINING TO DO SO.

1. PRODUCT OVERVIEW:

The 7.62 Sandman “S” and “L” series models are ruggedly constructed and machined from Stellite® and hardened stainless steel. The Sandman Ti™ features Stellite baffles and a direct thread only titanium tube. Overall performance is illustrated in Table #1.

	7.62mm		300 BLK		5.56mm	
	Measured	Reduction	Measured	Reduction	Measured	Reduction
Unsuppressed	167	N/A	160	N/A	165	N/A
Sandman-S™	140	-27	129	-31	136	-29
Sandman-L™	136	-31	124	-36	133	-32
Sandman-Ti™	136	-31	124	-36	133	-32

Test Equipment

G.R.A.S ¼" Pressure microphone Type 40BD // G.R.A.S 1/4" CCP Preamplifier Type 26CB // National Instruments NI USB-4432 - DAQ 102.4 kS/s, 24 Bits, ±40 V, IEPE // National Instruments - LabVIEW software

Among the product’s many design features, the Sandman “L” and “S” models offer a Patent Pending quick-disconnect mounting system that prevents seizing even after extended full-auto use. It’s easy to mount and easy to remove without any additional tools. The series is rated for use in everything from a .223 Remington to a .300 Win Mag. The “S” and “L” Sandman models are rated for full-auto use. With reasonable care, the service life of the suppressors should exceed 100,000 rounds.

GENERAL CONSIDERATIONS:

Ammunition: Ammunition will have a huge influence on how your new suppressor functions. Use good quality factory-new ammunition in your firearm. Avoid using wildcat or reloaded ammunition, as doing so may void your warranty.

Solvents and Lead Exposure: Exposure to toxic materials can occur while operating a firearm, so take certain precautionary steps on a regular basis. Washing of hands and exposed skin is a good practice. Solvents and lead can cause a variety of short and long term health issues – so be careful.

Concentricity: In order to reduce the risk of a baffle strike, it is important to ensure that your barrel threads are aligned concentrically with the bore axis of your host weapon’s barrel. If you do not have the means to verify this, it is strongly recommended that you have a competent gunsmith verify if for you.

2. INSTALLATION:



CHECK YOUR WEAPON'S CHAMBER AND MAKE CERTAIN THAT THE WEAPON IS UNLOADED AND THE MAGAZINE REMOVED BEFORE PROCEEDING ANY FURTHER. IF THERE IS ANY QUESTION OR DOUBT, CONSULT THE OPERATOR'S MANUAL APPLICABLE TO YOUR FIREARM AS TO THE PROPER PROCEDURE FOR CLEARING AND/OR UNLOADING YOUR WEAPON. DO NOT INSTALL YOUR NEW SUPPRESSOR ON A FIREARM WITH A CLOSED ACTION!

STEP ONE: PREPARATION

Your suppressor is intended to be attached to the muzzle end of your firearm. There are two methods for attachment depending on which model you purchased:

A. If you purchased the **Sandman Ti**, the suppressor will only thread directly onto barrels with existing 5/8-24 threads. We recommend checking tightness periodically. All direct thread suppressors will loosen with use. A loose suppressor will shift the point of impact because it can change the host weapon’s barrel harmonics and/or cause the loss of concentricity, and can also result in baffle strikes.

B. If you purchased the **Sandman-S or Sandman-L**, the key mount muzzle brake (5/8-24 supplied) is threaded onto the muzzle in place of your existing muzzle device (Illustration #1). Make certain that you utilize the included shims to align the 3 circular ports at the 12 o’clock position. Do not use a crush washer with your new suppressor as it may cause alignment issues. Additional key mount brakes with other common thread pitches may be purchased from your local dealer or by visiting www.DeadAirSilencers.com.

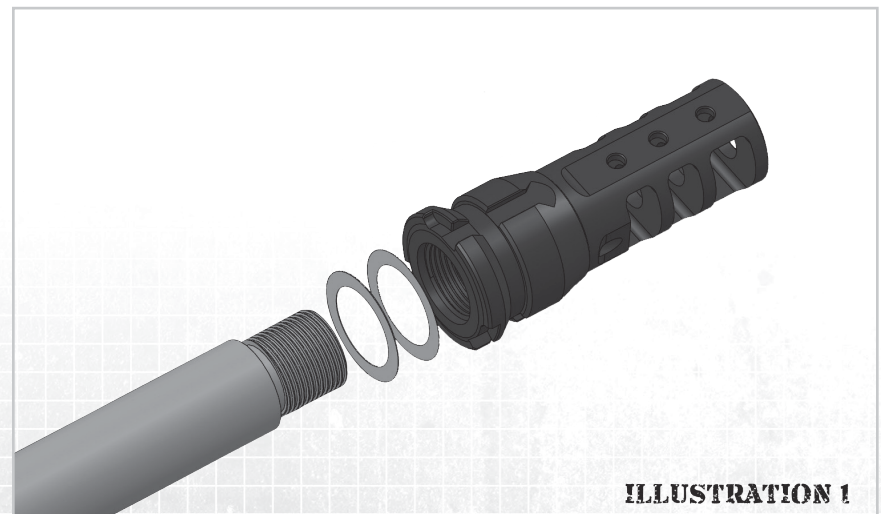

ILLUSTRATION 1

STEP TWO: KEY MOUNT INSTALLATION

First make certain to degrease the threads of the key mount muzzle brake and your host weapon's barrel threads before carefully threading the mount to the muzzle end of your firearm. Take care not to cross thread or force the brake to thread onto the firearm (Illustration #2). In the event that the key mount does not smoothly thread onto your firearm stop the installation process and immediately contact our Customer Service Department for further instruction. Once the key mount starts to thread onto the firearm, firmly tighten it onto the muzzle with a 3/4" wrench to approximately 25-35 ft/lbs of torque. Avoid using pliers or other similar tools as they may mar the finish of the key mount. Additionally, you can apply Rocksett to the threads of the host weapon's muzzle to further secure the key mount to your barrel, however, doing so may increase the difficulty of removing the key mount at a later time.



IF THE MOUNT DOES NOT SMOOTHLY THREAD ONTO YOUR FIREARM STOP THE INSTALLATION PROCESS AND CONTACT OUR CUSTOMER SERVICE DEPARTMENT. FAILURE TO PROPERLY INSTALL YOUR SUPPRESSOR COULD RESULT IN SERIOUS INJURY, DAMAGE TO THE SUPPRESSOR, THE HOST WEAPON, THE USER, AND/OR A THIRD PARTY.



OUR PRODUCTS ARE CALIBER SPECIFIC. UNLESS STATED OTHERWISE ON THE SUPPRESSOR ITSELF OR ON THE PACKAGING, THE 7.62 SUPPRESSOR WILL NOT FUNCTION SAFELY WITH ANY CARTRIDGE PRODUCING PRESSURES HIGHER THAN A .300 WIN-MAG. THIS PRODUCT CANNOT BE USED WITH ANY CALIBER GREATER THAN A .30 BORE DIAMETER. USE OF YOUR SUPPRESSOR OUTSIDE OF ITS INTENDED SCOPE COULD RESULT IN DAMAGE TO YOUR FIREARM, DAMAGE TO PROPERTY, BODILY INJURY, AND/OR DEATH AND WOULD VOID THE WARRANTY.

STEP THREE: MOUNTING THE SUPPRESSOR

Both the Sandman-S and Sandman-L connect directly to the key mount muzzle brake rather than to the host weapon muzzle itself (Illustration #3). Simply slide the threaded back cap of the suppressor over the key mount by aligning the "dot" marked locating lug with the ports at the 12 o'clock position and turn the tube clockwise until it locks into place. This will require a 1/2 to 3/4 rotation of the suppressor body.



STEP FOUR: REMOVING THE SUPPRESSOR

To remove the suppressor, turn the tube counter-clockwise until the suppressor disconnects (Illustration #4). The suppressor can only go on one way and come off one way as the tabs or lugs on the locking collar are not spaced equidistantly apart.

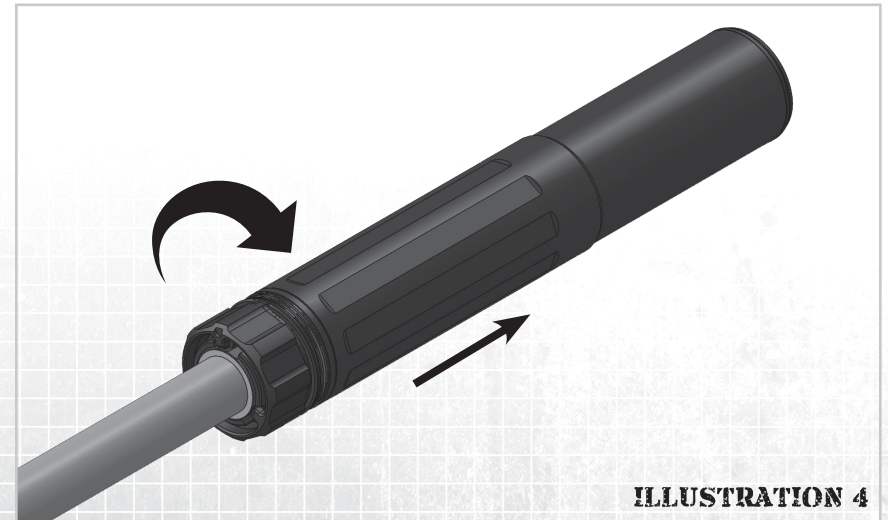



WHEN REMOVING THE SUPPRESSOR FROM YOUR FIREARM BE EXTREMELY CAUTIOUS AS THE TEMPERATURE OF THE SUPPRESSOR COULD CAUSE BURNS AND OR PERSONAL INJURY TO THE USER. MAKE SURE TO EITHER USE PROTECTIVE GLOVES OR WAIT UNTIL THE SUPPRESSOR COOLS BEFORE ATTEMPTING REMOVAL.

Before use, make sure that the suppressor is firmly and rigidly mounted to the firearm. Failure to do so could result in damage to your firearm and/or damage to the suppressor. Visually inspect the suppressor after it is mounted in order to confirm that it is mounted straight to the centerline of the bore and is otherwise not canted (Illustration #5), with the shoulders of the suppressor affixed at a 90 degree angle to the muzzle end.

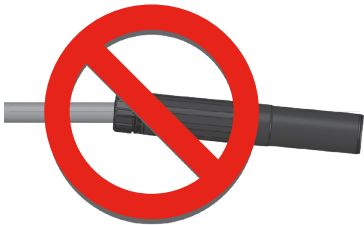

ILLUSTRATION 5

If the suppressor is not in line with the bore immediately stop the installation process and contact our Customer Service Department. Use of the suppressor while improperly mounted could cause irreparable harm to your suppressor and will cause poor performance and/or reduced accuracy.



DO NOT OPERATE YOUR SUPPRESSOR UNDER ANY CIRCUMSTANCES IF IT IS NOT PROPERLY MOUNTED ON THE FIREARM! TO DO SO COULD RESULT IN SERIOUS DAMAGE, DEATH AND/OR INJURY TO THE OPERATOR AND THIRD PARTIES. IT WILL RESULT IN DAMAGE TO THE SUPPRESSOR AND WILL GROSSLY AFFECT PERFORMANCE AND/OR ACCURACY AND MAY VOID WARRANTY.

3. BREAK IN:

Once your suppressor is properly mounted it may require some minimal break in. First shot cold performance can be compromised until the suppressor accumulates some unburnt powder and lead. This is normal and generally resolves itself after the first 5-10 shots. Thereafter the suppressor will perform at an optimal level without further break in requirements. The type of ammunition that you use and the atmospheric conditions present when you shoot the weapon can have a huge influence over performance.

4. DISASSEMBLY & CLEANING:

Typically there is very little maintenance needed with respect to your suppressor other than to keep the threads clean and to wipe down the outside with good quality gun oil. The suppressor has a Cerakote™ exterior finish. The finish is extremely durable but some care should be taken concerning exposure to various solvents. Always test a small area before applying a solvent to the suppressor as a whole. Soaking the suppressor in any solvent for an extended period may harm the Cerakote finish of your suppressor and is unnecessary as center fire rifle suppressors do not require such cleaning procedures.

Disassembly of your suppressor is not generally required or recommended. Taking your suppressor apart for its own sake may result in compromised performance, baffle strikes, and/or lost parts. Your suppressor was assembled at the factory by trained technicians to certain technical specifications and settings. Random disassembly of the unit may result in a voiding of your suppressor's express warranties.

In the rare event that disassembly is necessary (debris lodged in the threads or inside the suppressor itself), both the Sandman "L" and "S" feature locking collars that are threaded onto the body of the suppressor and held under tension with a wave spring. To disassemble, simply pull the locking ring towards the front end cap so that the locking collar can be turned counter clockwise so that the stop tabs / lugs on the locking collar and locking ring clear one another.

To reassemble, make sure to turn the collar clockwise fully into its furthest clockwise rotation point past the locking ring tab. You will have to make several full rotations. If the locking collar is not completely and fully indexed it will not engage on the key mount as designed.

The front cap of your suppressor can be removed. Unless you have damaged the front cap by either dropping the suppressor or suffering a baffle strike DO NOT REMOVE THE CAP. If it requires removal, remove the cap by turning it counter clockwise until it disengages from the suppressor body. When you re-install the cap pay careful consideration not to cross-thread the cap. Cross-threading the cap can cause concentricity issues and may cause damage to the body of the suppressor, the front cap, or both.

Do not run cleaning patches through the suppressor as they may become lodged in the suppressor, thus affecting performance. Any questions concerning the performance or care of your suppressor should be directed to the Customer Service Department at 844-293-6778.

5. DISCLAIMER:

The manufacturer is not responsible for damages or injuries due to the misuse or unintended use of its products. This product is potentially dangerous and, as such, adequate safety precautions must be taken in order to avoid damage to your firearm, damage to third parties, bodily injury or death. Please consult our website for further details at:

WWW.DEADAIRSILENCERS.COM OR CALL 844-293-6778

6. WARRANTY:

We provide a lifetime warranty against all manufacturing defects and damages caused by the normal use of this product. The manufacturer will repair or replace free of charge any suppressor manufactured by, or at the direction of, Sound Moderation Technologies. The product is sold "as is" with no further implied contractual rights or warranties beyond those expressly stated herein.

The warranty does not apply to certain conditions or acts. It is at the sole discretion and determination of Sound Moderation Technologies if a particular defect or condition is covered by this warranty. Conditions not covered include, but are not limited to: modifications, abuse, neglect, use of defective ammunition, use of improperly sized ammunition, and criminal conduct. Sound Moderation Technologies assumes no liability for damages or bodily injury caused by such acts or omissions as previously described. Abuse and neglect are defined as usage outside of the reasonable scope for which the product is intended, thus contributing to the accelerated and unreasonable premature wear of the suppressor itself.

If a repair is indicated then the owner must contact our Customer Service Department at 844-293-6778. A Dead Air Silencers representative will make arrangements for return of the suppressor at manufacturer's shipping expense. **DO NOT SHIP THE SUPPRESSOR FOR REPAIR WITHOUT FIRST CONTACTING CUSTOMER SERVICE AND DO NOT SHIP IN ANY EVENT WITHOUT A COPY OF THE APPROVED BATF FORM.** When you ship the suppressor back to the manufacturer, please include a detailed statement concerning the type of defect or malfunction encountered and describe the ammunition used and type of host weapon the product was used on or attached.

If for any reason your suppressor is not eligible for repair or replacement, you may purchase a replacement suppressor for 50% off the MSRP for a same or similar suppressor. Please contact our Customer Service Department for further details and requirements.

7. LAWFUL USE AND POSSESSION:

Your new suppressor is an NFA weapon and is not legal to own or possess in certain jurisdictions. Sound Moderation Technologies does not offer any express or implied promises or affirmations concerning the use, possession, or ownership of your suppressor. If you have any questions concerning the ownership, possession, or use of your suppressor contact the chief local law enforcement officer in the jurisdiction in which you reside or your local BATF office for further information concerning the ownership, use, and possession of NFA controlled weapons.

HELPFUL OWNERSHIP INFORMATION

ALWAYS MAINTAIN A COPY OF THE APPLICABLE BATF DOCUMENTS TO YOUR SUPPRESSOR WITH THE SUPPRESSOR ITSELF WHENEVER TRANSPORTING OR USING YOUR SUPPRESSOR. FAILURE TO DO SO COULD RESULT IN CONFUSION, PROSECUTION, OR CONFISCATION OF YOUR NFA CONTROLLED WEAPONS. BETTER SAFE THAN SORRY.

8. CONTACT INFORMATION:

You can contact us directly by telephone at 844-293-6778, or visit our website at www.deadairsilencers.com.

Thank you once again for supporting our products and feel free to contact us with any inquiries or concerns that you might have.





No Quarter™



⚠ Warning: This product can expose you to chemicals including lead, which is known to the State of California to cause cancer and birth defects or other reproductive harm. For other information go to www.P65Warnings.ca.gov